

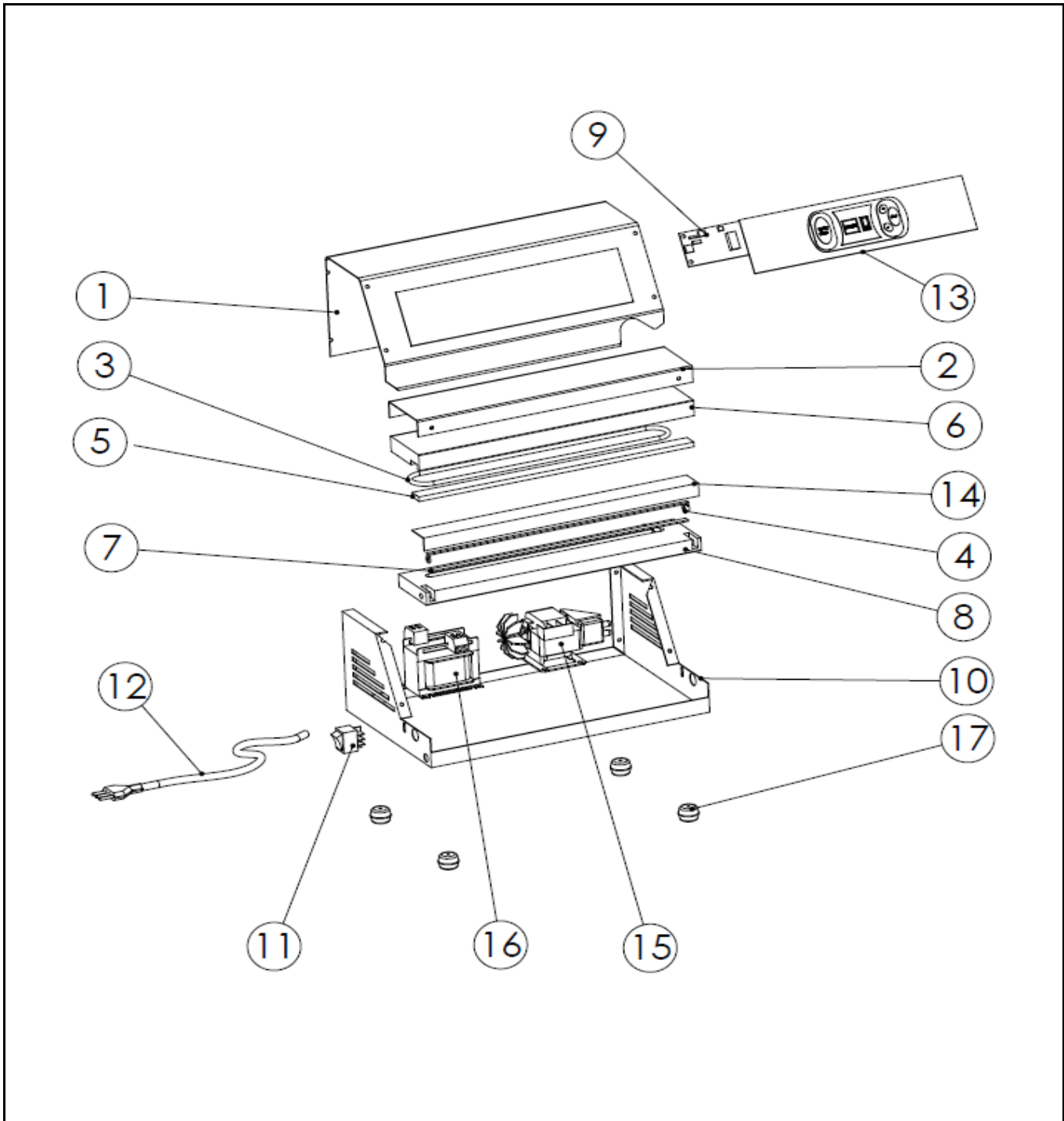

Drawing

 <p>Hendi B.V. Steenoven 21 3911 TX Rhenen The Netherlands</p>	Batch #	Appliance part#
	660122 and up	970447
	Description	
	Vacuum packaging machine Profi Line	

Date	06-04-2016	Revision #	Revision version
Revision	First bill of materials (BOM)		



Bill of materials (BOM)

 Hendi B.V. Steenoven 21 3911 TX Rhenen The Netherlands	Batch #	Appliance part#
	660122 and up	970447
	Description	
	Vacuum packaging machine Profi Line	

Date	06-04-2016	Revision #	Revision version
Revision	First bill of materials (BOM)		

Item	Description	Part#	Quantity	Remark	Picture
1	Top cover	n/a	1		
2	Upper cover	n/a	1		
3	Gasket lid	939628	1		
4	Sealing wire	932193	1	(sold p/m)	
5	Silicone sealing	932179	1		
6	Polyethylene plate	n/a	1		
7	Silicone sealing (sealing wire)	932186	1	(sold p/m)	
8	Polyethylene plate	n/a	1		
9	Display pcb	939635	1		
10	Housing	n/a	1		
11	Switch	939642	1		
12	Powercord	n/a	1		
13	Display sticker	n/a	1		
14	Teflon tape	939673	1	(sold p/m)	
15	Vacuum pomp 40L/min	939710	1		
16	Transformer 85W	939680	1		
17	Rubber feet	939697	4	(sold p/pc)	

n/a -> not available

nss -> not sold separately

Circuit diagram

 <p>Hendi B.V. Steenoven 21 3911 TX Rhenen The Netherlands</p>	Batch #	Appliance part#
	660122 and up	970447
	Description	
	Vacuum packaging machine Profi Line	

Date	06-04-2016	Revision #	Revision version
Revision	First bill of materials (BOM)		

